TECHNICAL SPECIFICATIONS

M2RC Series

High Efficiency / Direct Vent Condensing Upflow Gas Furnace

Induced Draft - 90+ AFUE Input 80,000 & 100,000 Btuh

The high efficiency upflow gas furnace is especially designed for Manufactured Housing. It may be installed in a utility room or enclosed in a closet. ETL design certified for use in the United States and Canada, this product is truly designed with the installer and the consumer in mind.

Features and Benefits

- 100% fired and tested — All units and each component (both mechanical and electrical) are tested on the manufacturing line.
- Clean and quiet operation — Due to the unique design of in-shot burners, location of inducer and use of insulation.
- Fixed 30 second blower delay at burner start-up assures a warm outlet air temperature at furnace start-up. Adjustable blower off settings (60, 90, 120 and 180 seconds).
- Fixed 30 second post purge increases life of heat exchanger.
- Dependable, shock-mounted hot surface ignitor — Innovative application of an appliance type ignitor with a 20 year history of reliability, assures no callbacks because of handling.
- Tubular primary heat exchanger — Heavy gauge aluminized steel heat exchanger assures a long life.
- Stainless steel secondary heat exchanger assures a long life.
- 90 second fixed cooling cycle blower-off delay (TDR) increases cooling performance when matched with a NORDYNE coil.
- Approved for direct vent furnace, category IV venting system — May be vertically or horizontally vented using a two-pipe system for maximum flexibility in installation.
- Multi-speed direct drive blower — Designed to give a wide range of cooling capacities. 40VA transformer included.
- LP convertible — Simple burner orifice and gas valve regulator change for ease of convertibility.
- Diagnostic light flashes identify limit failure, pressure switch failure and improper ground and polarization — for easy troubleshooting.
- New two piece door design enhances furnace appearance and uses screw fasteners for great fit and accessibility.
- 3 amp fuse protection against high and low voltage shorts; protects transformer and control board.
- Low voltage terminal board for easy field wiring.

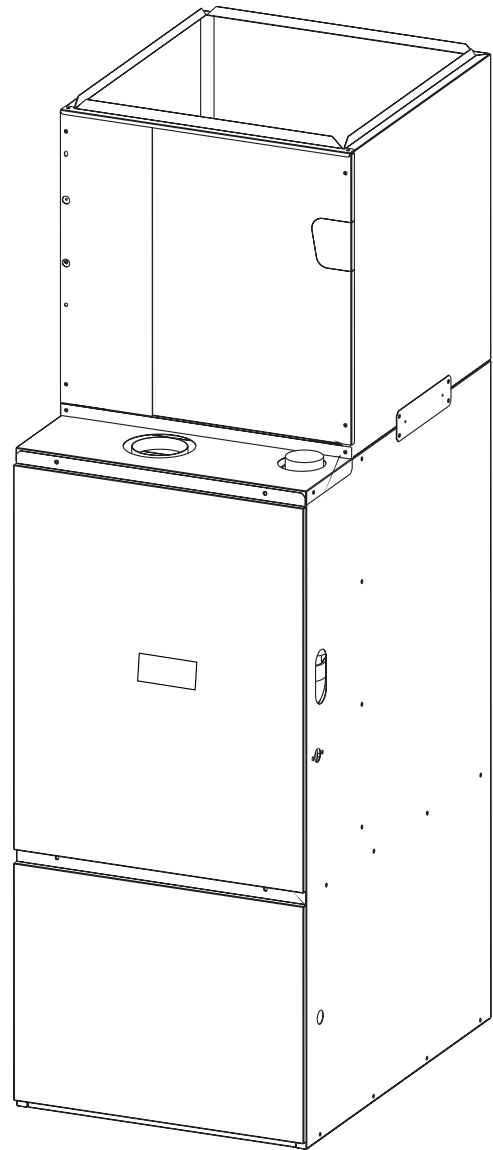

FEATURES

High Efficiency Upflow 90+ Gas Furnace

Upflow Furnace

- 1 Manifold
- 2 Flame Sensor / Ignitor (Not Shown)
- 3 Gas Valve
- 4 Flame Roll-out Switch
- 5 Pressure Switch
- 6 Control Board
- 7 Blower Door Switch (Not Shown)
- 8 Vent Safety Switch
- 9 Transformer
- 10 Supply Air Limit Switch
- 11 Circulating Air Blower Assembly
- 12 Induced Draft Blower
- 13 J Trap, Hard Tube
- 14 In-Line Drain Assembly
- 15 Burner Box Assembly
- 16 Front Header Box
- 17 A/C Coil Box
- 18 Filter (Not Shown)
- 19 Attachment Bracket

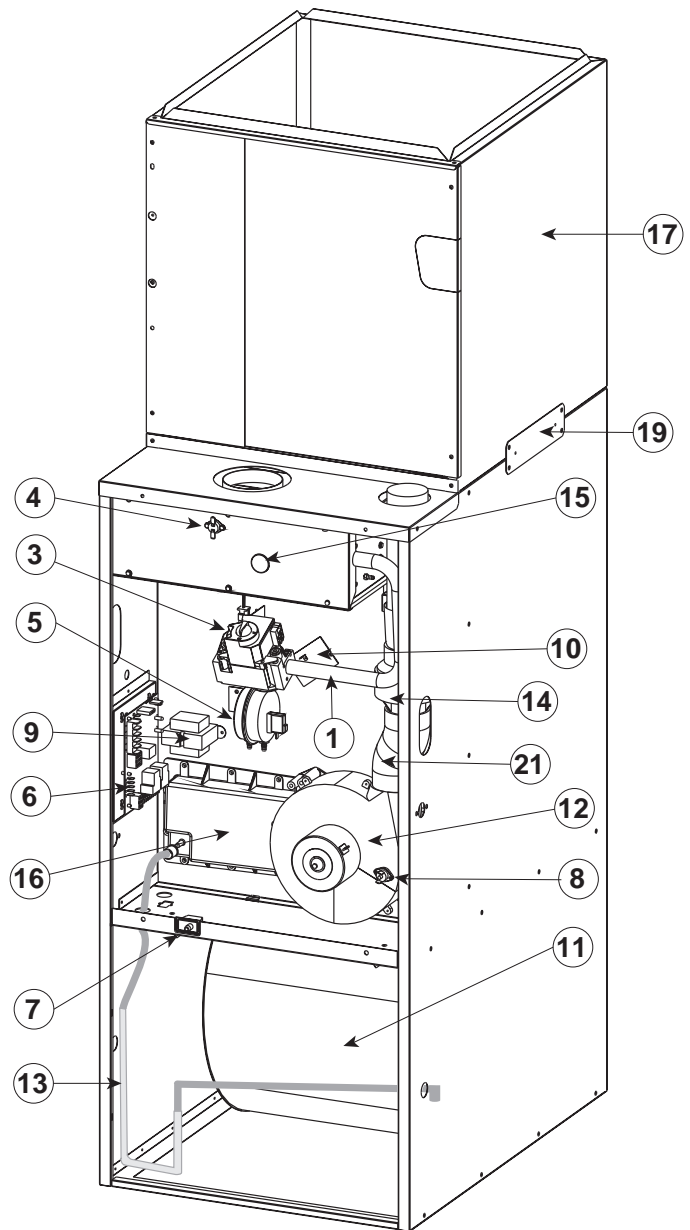

SPECIFICATIONS

M2RC MODEL NUMBERS:	-080A-16	-100A-16
Input-Btuh (a)	80,000	100,000
Heating Capacity - Btuh	72,000	90,000
AFUE	90+	90+
Blower D x W	10 x 10	10 x 10
Motor H.P. -Speed -Type	1/2 - 4 -PSC	1/2 - 4 -PSC
Motor FLA	7.9	7.9
Maximum Ext. SP - In. W.C.	0.5	0.5
Temperature Rise Range - °F	35 - 65	35 - 65

STANDARD EQUIPMENT

Direct vent; draft inducer; pressure switch; redundant main gas control; hot-surface ignition; timed ON/OFF blower controls (TDR); 40VA transformer for air conditioner application; limit controls; direct drive motor; all models can be converted to use LP (propane) gas.

Note: All models are 115V, 60 Hz. Gas Connections are 1/2" N.P.T. AFUE = Annual Fuel Utilization Efficiency
 (a) Ratings to 2,000 ft. Over 2,000 ft. reduce 4% for each 1,000 ft. above sea level.

DIMENSIONS

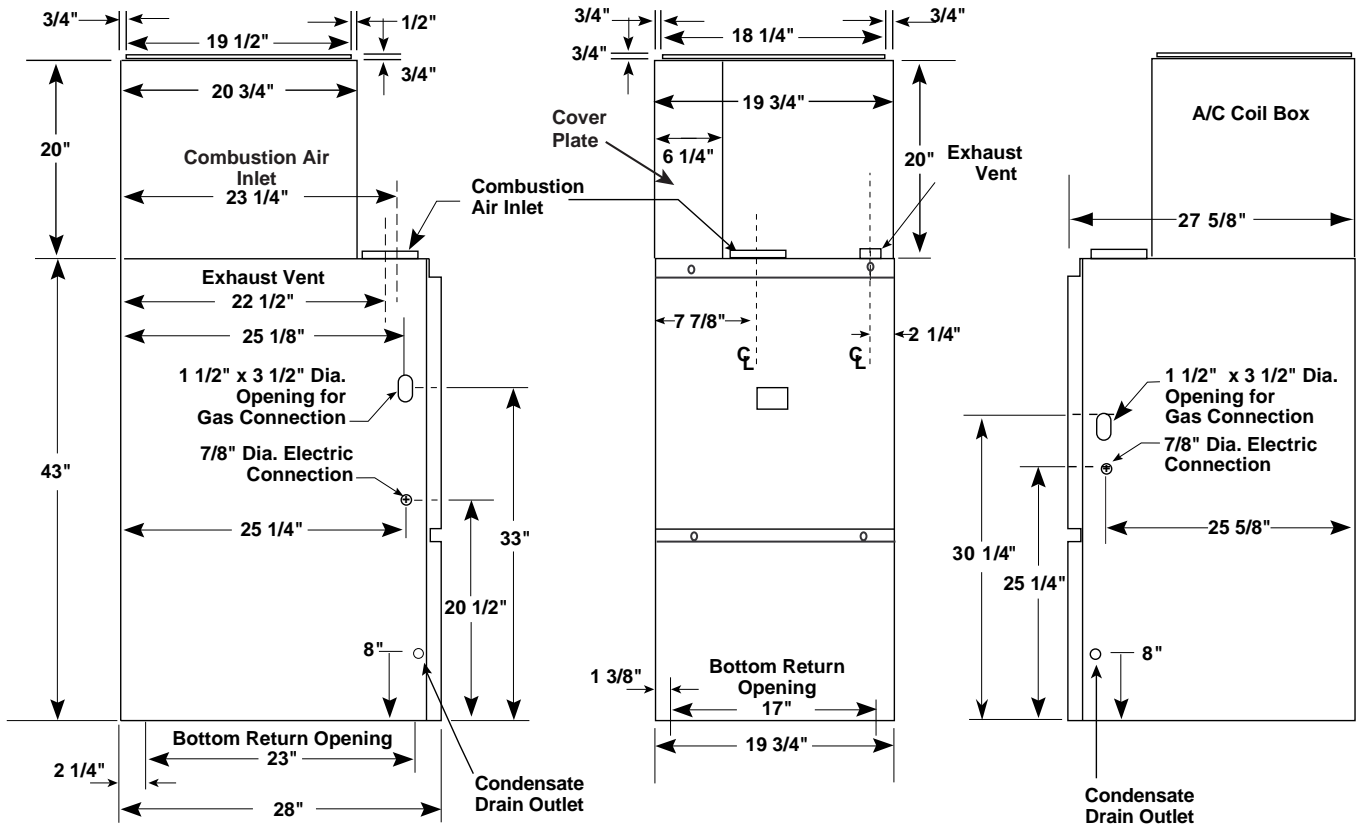

Model	Furnace Input (Btuh)	Shipping Weight (lbs)
M2RC - 080A - 16 - B(†)	80,000	160
M2RC - 100A - 16 - B(†)	100,000	168

†Can be N or L

BLOWER PERFORMANCE

Model No. M2RC	Blower Speed	External Static Pressure - Inches Water Column									
		0.1		0.2		0.3		0.4		0.5	
		CFM	Rise	CFM	Rise	CFM	Rise	CFM	Rise	CFM	Rise
080A-16	High *	1840	-	1780	-	1700	-	1630	-	1550	-
	Med-High	1600	43	1560	44	1470	47	1400	49	1350	51
	Med-Low **	1380	50	1350	51	1300	53	1250	55	1190	58
	Low	1100	-	1050	-	1000	-	950	-	900	-
100A-16	High *	1910	-	1860	-	1780	-	1700	-	1620	-
	Med-High **	1640	53	1620	54	1540	57	1480	59	1420	62
	Med-Low	1440	61	1410	62	1370	64	1320	-	1270	-
	Low	1230	-	1210	-	1180	-	1140	-	1090	-

* Factory wired cooling speed tap.

** Factory wired heating speed tap.

- Not Recommended

NOTE: Data is for operation with filters.

IDENTIFICATION CODE

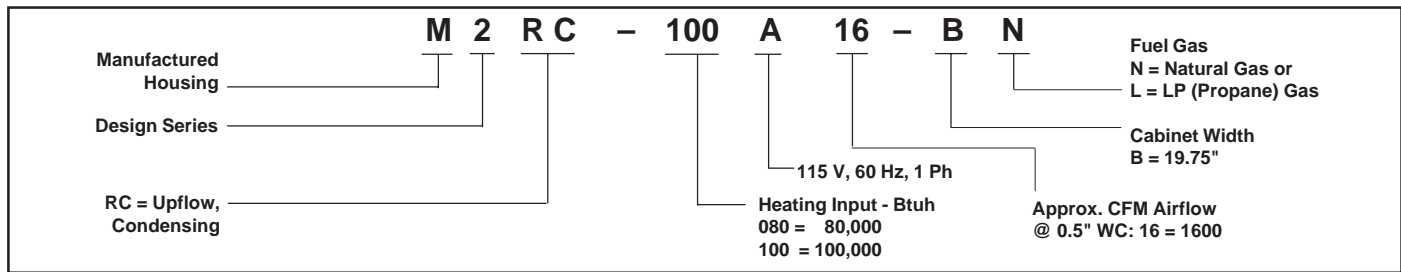

VENTING

All models are approved for both vertical and horizontal direct (2 pipe) venting applications. See Vent Table below for specified sizes and allowable lengths.

VENT TABLE

APPLICATION	DIRECT VENT, DUAL PIPE LENGTH (ft.) with 1 long radius elbows on each pipe.*	
	Inlet/Outlet	
PVC, CPVC or ABS SCH. 40 Pipe Size	3"	3"
Model M2RC 080	90	90
Model M2RC 100	90	90

* NOTE:

1. Subtract 3.5 ft. for each additional 3" elbow.
2. Two 45 degree elbows are equivalent to one 90 degree elbow.
3. One short radius elbow is equivalent to two long radius elbows.
4. Do not include termination elbows in calculation of vent length.
5. This table is applicable for elevations from sea level to 2000 ft. For higher elevations decrease vent pipe lengths by 8% per 1000 ft. of altitude.
6. Only the above pipe materials are approved for use with M2 Condensing Furnaces.

ACCESSORY VENT KITS

3" PVC Horizontal Exterior Vent Mounting Kit	9023750
Neutralizer Kit- All Models	9023770

High Efficiency 90+ with Honeywell VR Gas Valve	
Kit	Order Number
Fossil Fuel Kit	914762
A/C Coil Box	914958
Sloped Roof VentilAire III Kit	914098
Sloped Roof VentilAire IV Kit	914229
Soffit VentilAire Kit	917201
Concentric Vent Termination Kit (for horizontal and vertical venting)	903578

